

Instruction Manual

α pha-pH500

2-Wire pH/ORP Transmitter

pH/mV/°C meter



OAKTON®

**EUTECH
INSTRUMENTS**

Technology Made Easy...

ISO 9001
CERTIFIED

68X216829 Rev 3 May 06

Preface

This manual serves to explain the use of the pH 500 transmitter. It functions in two ways, firstly as a step by step guide to help you to operate the transmitter. Secondly, it serves as a handy reference guide. It is written to cover as many anticipated applications of the transmitter as possible. If there are doubts in the use of the transmitter, please do not hesitate to contact the nearest Authorized Distributor.

Eutech Instruments / Oakton Instruments will not accept any responsibility for damage or malfunction to the transmitter caused by improper use of the instrument.

Remember to fill in the guarantee card and mail it back to your authorized distributor.

The information presented in this manual is subject to change without notice as improvements are made, and does not represent a commitment on the part of Eutech Instruments / Oakton Instruments.

Copyright © 2002

All rights reserved

Eutech Instruments / Oakton Instruments

TABLE OF CONTENTS

| | | |
|------------------|---|------------------|
| <u>1</u> | <u>INTRODUCTION</u> | <u>1</u> |
| <u>2</u> | <u>PREPARATION</u> | <u>2</u> |
| 2.1 | Power Supply Requirements (SL2 Position) | 3 |
| 2.2 | Connecting the Electrode and Temperature Probe (SL1 Position) | 3 |
| <u>3</u> | <u>INSTALLATION</u> | <u>5</u> |
| 3.1 | Wall Mount | 5 |
| 3.2 | Panel Mount | 6 |
| <u>4</u> | <u>DISPLAY AND KEYPAD FUNCTIONS</u> | <u>7</u> |
| 4.1 | Display | 7 |
| 4.2 | Keypad | 8 |
| <u>5</u> | <u>CALIBRATION</u> | <u>9</u> |
| 5.1 | Preparing the Transmitter for Calibration | 9 |
| 5.2 | pH Calibration | 10 |
| 5.3 | Relative mV Calibration | 11 |
| 5.4 | Temperature Calibration | 11 |
| <u>6</u> | <u>ADVANCED SETUP FUNCTIONS</u> | <u>12</u> |
| 6.1 | Offset Setting (Unavailable in ORP mode) | 12 |
| 6.2 | Output Range Setting | 13 |
| 6.3 | Temperature Compensation Setting (Unavailable in ORP mode) | 14 |
| 6.4 | HOLD Current Setting | 17 |
| 6.5 | Out-of-Range Current Setting | 17 |
| 6.6 | Configuration | 18 |
| <u>7</u> | <u>PROBE CARE AND MAINTENANCE</u> | <u>20</u> |
| <u>8</u> | <u>TROUBLE SHOOTING GUIDE</u> | <u>22</u> |
| <u>9</u> | <u>SPECIFICATIONS</u> | <u>23</u> |
| <u>10</u> | <u>TECHNICAL DIMENSIONS</u> | <u>24</u> |
| <u>11</u> | <u>ACCESSORIES</u> | <u>25</u> |
| <u>12</u> | <u>WARRANTY</u> | <u>27</u> |
| <u>13</u> | <u>RETURN OF ITEMS</u> | <u>27</u> |

1 INTRODUCTION

Thank you for selecting a pH 500 pH/ORP Transmitter. This transmitter is a microprocessor-based instrument that is designed to be sturdy and user-friendly. It is capable of measuring pH, mV and temperature.

This transmitter has many user-friendly features – all of which are completely accessible through the water-resistant membrane keypad. Your transmitter includes an instruction manual and a warranty card.

Please read this manual thoroughly before operating your transmitter.

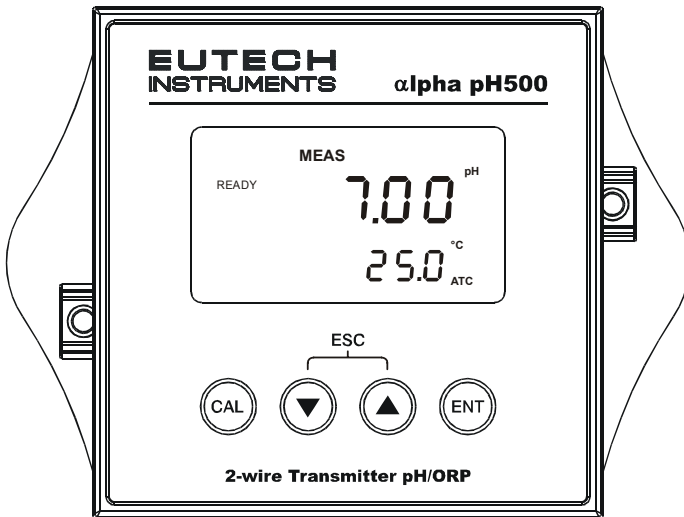

2 PREPARATION

Remove screws from the four corners at the back of the Transmitter, and remove back cover.

Connectors should be exposed as follows:

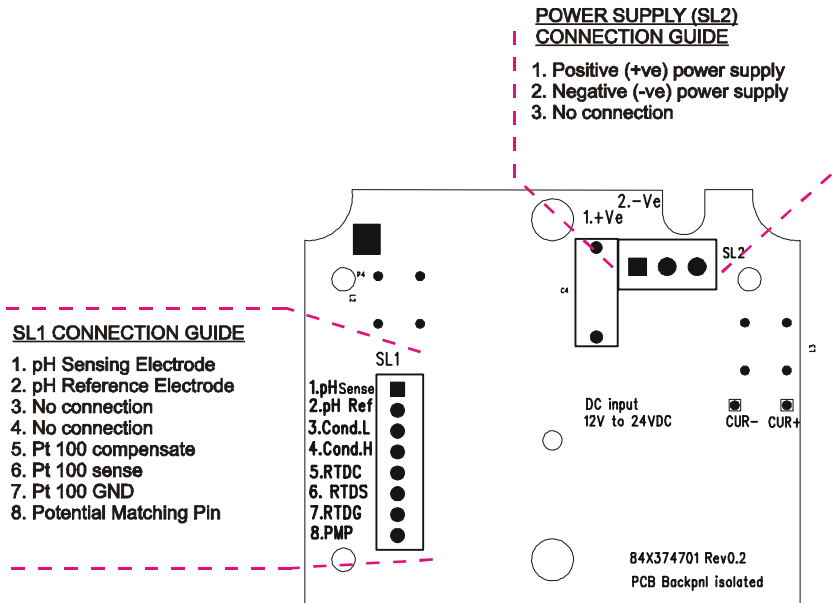

Figure 1 – Connection Guide

All wiring is done on 2 detachable connectors: –

1. 9-pin connector (located on SL1 position) for pH electrode, temperature sensor and potential matching pin (PMP); &
2. 3-pin connector (located on SL2 position) for power supply.

Using a suitable screwdriver, loosen screws from top of connector.

When inserting the wires, always hold connector with top screws facing up.

2.1 Power Supply Requirements (SL2 Position)

This transmitter requires a 12 to 24V DC power supply. Other Transmitters and/or a chart recorder may be connected in series.

1. Insert positive loop wire from power supply to pin 1, tighten screw.
2. Insert negative loop wire to pin 2, tighten screw. This wire may be linked to a chart recorder or to negative terminal of power supply.

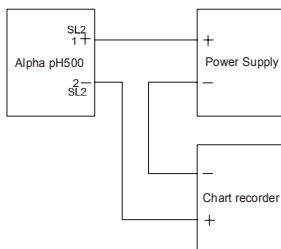

2.2 Connecting the Electrode and Temperature Probe (SL1 Position)

2.2.1 To connect the pH or ORP electrode:

The pH transmitter accepts any combination electrode for pH or ORP measurements

1. Remove BNC connector from cable. Two wires will be exposed.
2. Strip insulation, just enough to expose bare wires.

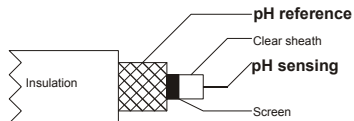

IMPORTANT: For pH/ORP sensing cable, remember to strip the inner black layer (screen) and expose the clear plastic sheath.

- 3.1. Insert pH sensing cable into pin 1 of connector. Tighten screw.
- 4.2. Insert pH reference cable into pin 2 of connector. Tighten screw.

NOTE: Instead of removing the BNC connection, Oakton offers an optional adapter (part number 05994-90 BNC to Spade Lug adapter) that can be used.

2.2.2 To connect temperature probe:

For Automatic Temperature Compensated (ATC) pH readings, a 100 Ω Pt RTD temperature probes can be used. Industrial pH electrodes are often offered with ATC, which will typically be bare wires.

3-wire probe

- 1. Insert Pt 100 sense wire to pin 5 of connector. Tighten screw.
- 2. Insert Pt 100 input wire to pin 6 of connector. Tighten screw.
- 3. Insert Pt 100 return wire to pin 7 of connector. Tighten screw.

2-wire probe:

- 1. Take a small length of wire and short pins 5 and 6 of connector. Insert Pt 100 sense wire into pin 6 of connector and tighten screws.
- 2. Insert Pt 100 return wire to pin 7 of connector. Tighten screw.

IMPORTANT: Temperature probe should always be together with pH probe, even during calibration. Make sure no bare wires are exposed and all screws are tightened for proper contact.

2.2.3 To connect Potential Matching Pin (Liquid electrical interferences):

Connect the additional wire from the electrode to pin 8. Transmitter must be configured to 'Symmetrical mode of operation' - Please refer to 'Advanced Setup Functions', Section 6.6.2 – Selecting Asymmetrical or Symmetrical Mode of Operation.

3 INSTALLATION

3.1 Wall Mount

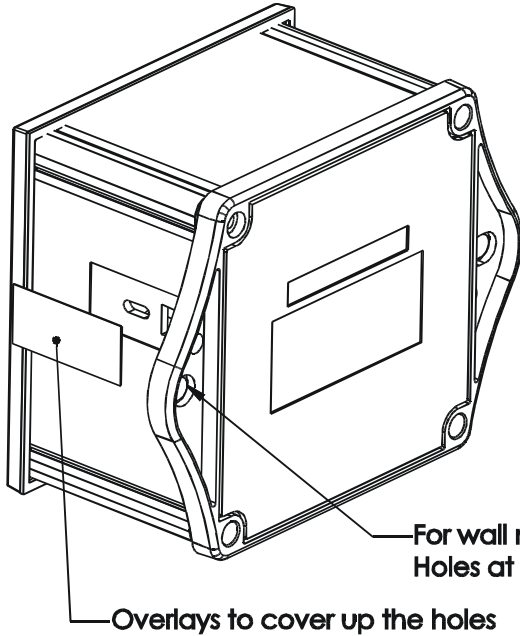

For wall mount:-
Holes at both side have to pierce thru.

Overlays to cover up the holes

3.2 Panel Mount

1. Prepare panel cut-out of 92.0 mm by 92.0 mm

2. Remove back cover of transmitter and slide it through panel cut-out

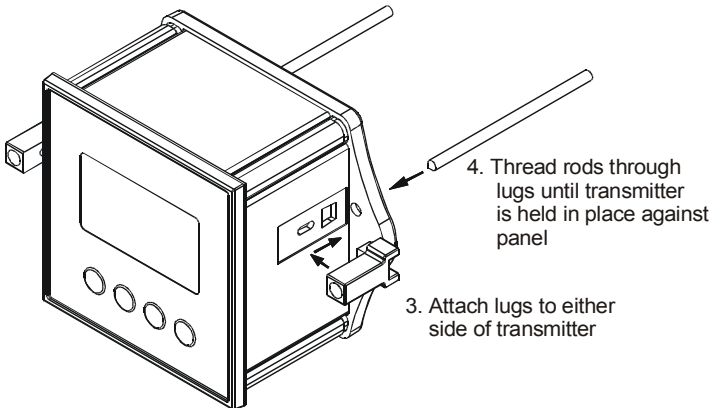
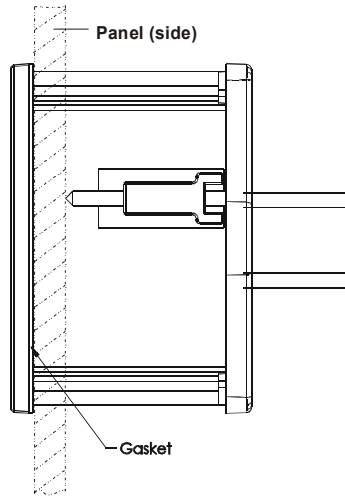

4 DISPLAY AND KEYPAD FUNCTIONS

4.1 Display

The LCD has a primary and secondary display.

- The primary display shows the measured pH, mV or Relative mV value.
- The secondary display shows the measured temperature. In Calibration mode, pH buffer values are displayed here; while measured mV values are displayed in the ORP Calibration mode.

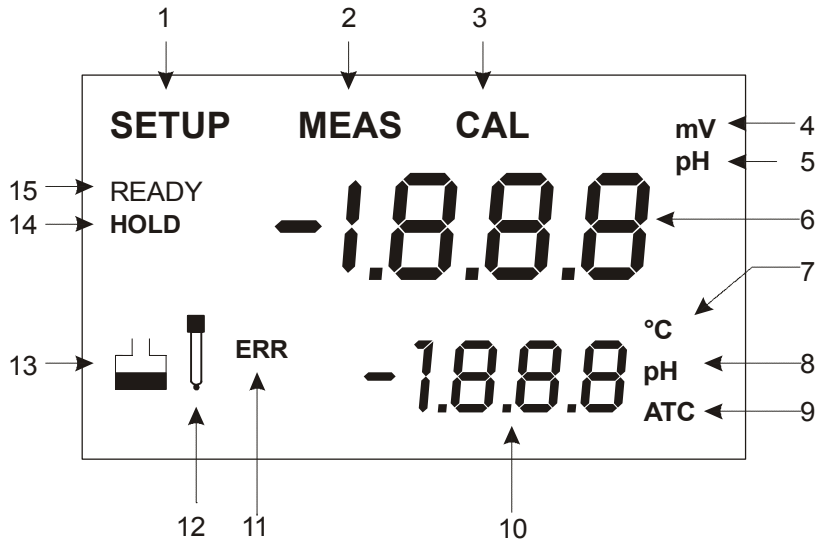

| | | |
|-------------------------------|---|----------------------|
| 1. SETUp mode indicator | 6. Primary display | 11. ERRor indicator |
| 2. MEASurement mode indicator | 7. Temperature indicator | 12. Probe indicator |
| 3. CALibration indicator | 8. pH buffer selection indicator | 13. Buffer indicator |
| 4. mV indicator | 9. Automatic Temperature Compensation indicator | 14. HOLD indicator |
| 5. pH indicator | 10. Secondary display | 15. READY indicator |

4.2 Keypad

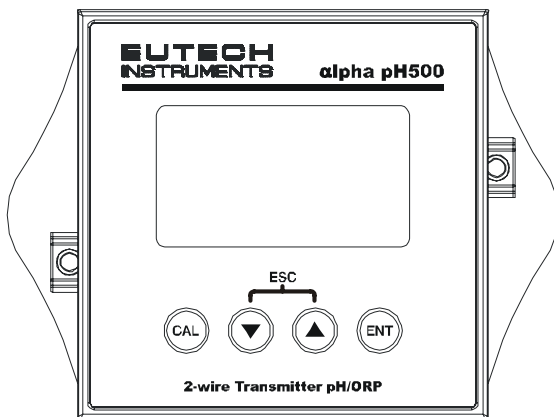

The four-button keypad allows easy and quick operations of the Transmitter.

| Key | Function |
|-------|--|
| CAL | Brings you directly into the Calibration mode. 1.If you were in pH Measurement mode, press CAL to enter pH Calibration mode. 2.If you were in mV Measurement mode, press CAL to enter mV Calibration mode. |
| ▲ / ▼ | 1.To scroll through the various submenus 2.To increment/decrement values or toggle between options (in the SETUP/CAL modes) 3.When pressed together, serves as escape function to return to MEAS mode from any point (CAL or SETUP modes). |
| ENT | 1.To confirm your calibration values in Calibration mode. 2.To confirm selections in SETUP mode. While in MEAS mode, pressing ENT takes you directly to SETUP submenu |

5 CALIBRATION

5.1 Preparing the Transmitter for Calibration

Before starting calibration, make sure you are in the correct measurement mode. When you switch on the transmitter, the transmitter starts up in the units last used. For example, if you shut the transmitter off in “mV” units, the transmitter will read “mV” units when you switch the transmitter on.

Be sure to remove the protective electrode storage bottle or rubber cap of the electrode before calibration or measurement. If the electrode has been stored dry, wet the electrode in tap water for 10 minutes before calibrating or taking readings to saturate the pH electrode surface and minimize drift.

Wash your electrode in deionized water after use, and store in electrode storage solution. If storage solution is not available, use pH 4.01 or 7.00 buffer solution.

Do not reuse buffer solutions after calibration. Contaminants in the solution can affect the calibration, and eventually the accuracy of the measurements.

The transmitter features two internationally recognized buffer standards. Select the buffer standard you require in the CAL mode. Select from the following buffer options:

- First-point: pH 7.00 (USA buffer) or pH 6.86 (NIST buffer).
- Second point: pH 4.01, 9.18, or 10.1.

NOTE: When transmitter is entered into the CAL mode, the 4/20 mA output current will be automatically held. ‘HOLD’ will be displayed on LCD. After Calibration and transmitter is returned to MEAS mode, the ‘HOLD’ is automatically released. Please refer to page 17, section 6.4 for more details.

5.2 pH Calibration

A complete 2-point CAL is required for this Transmitter. If Calibration is aborted after 1st calibration point, transmitter reverts to previous Calibration data.

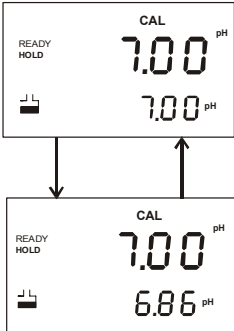

1. Rinse probe thoroughly with de-ionized water or a rinse solution. Blot excess liquid.
2. Dip probe into calibration buffer. End of probe must be completely immersed into buffer. Stir probe gently to create a homogeneous sample.
3. From pH MEAS mode, press CAL to enter pH calibration mode. CAL indicator will be shown. Primary display will show measured reading while secondary display will indicate the pH standard buffer solution.
4. Press ▲ or ▼ keys to select either pH 7.00 (USA) or pH 6.86 (NIST) standard buffers. This is the first point, Offset calibration.
5. Wait for measured pH value to stabilize. Press ENTER to confirm calibration. Transmitter is now calibrated to current buffer.
6. Rinse probe with de-ionized water or rinse solution, and place in next pH buffer (pH 4.01, pH 9.18 or pH 10.01).
7. Repeat steps 5 and 6.
8. Upon successful Calibration, transmitter displays Slope (primary display, in mV) and Offset (secondary display, in pH) of electrode.
9. Press ENTER to return to MEAS mode. Transmitter has been calibrated. Rinse electrode and proceed with measurements.



NOTES:

To exit from pH calibration mode without confirming calibration, press ▲ and ▼ keys together.

If selected buffer value is not within ± 1.0 pH from measured pH value: electrode and buffer icon blink and ERR annunciator appears in lower left corner of display.

5.3 Relative mV Calibration

1. From the ORP MEAS mode, press CAL key. CAL indicator appears at top of LCD. Primary display shows relative mV reading and secondary display shows absolute mV value.
2. NOTE: If you have never calibrated relative mV or if the transmitter has been reset, the value shown in the primary display is the same as the absolute mV value.
3. Press ▲ or ▼ keys to enter the relative mV value that matches your desired reading (only the readings in the primary display changes).
4. Press ENTER key to confirm. Transmitter will now display the offset in the readings.
- 4.5. Press ENTER key to return to MEAS mode.

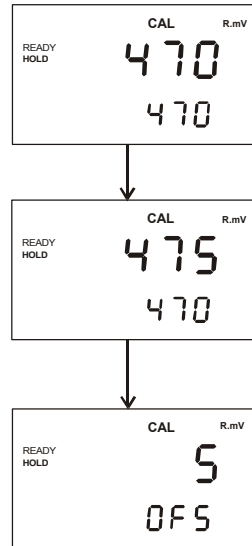

5.4 Temperature Calibration

Temperature calibration is available only in the pH measurement mode and when ATC probe is available.

Calibrate temperature probe only if temperature value displayed on transmitter is different from that of a calibrated thermometer. Please refer to section 6.3.1 for further information.

6 ADVANCED SETUP FUNCTIONS

The advanced setup mode lets you customize your transmitter's preferences and defaults. This transmitter features different sub groups that organize all setup parameters.

The sub-groups are:

6.1 Offset Setting (Unavailable in ORP mode)

As a result of the continuous measurement and the application concerned, it may not be convenient to remove the electrode for calibration. In such cases, an on-line Offset adjustment is offered.

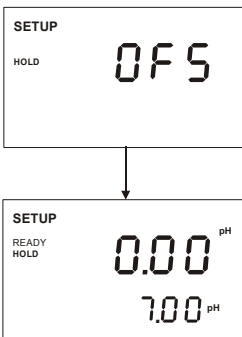

1. Press ENT key. Transmitter displays 'OFS'. Press ENT again. Upper display shows amount of offset, in terms of pH; lower display shows current measured pH value.
2. Use ▲ or ▼ keys to introduce offset to pH readings. As the lower measured reading changes, upper display records the amount of offset. Maximum of ± 2.00 pH offset is allowed.
3. Press both ▲ or ▼ keys together to return to 'MEAS' mode.

6.2 Output Range Setting

Output of pH 500 transmitter is via the 2-wire power supply loop. Both the 4 mA and 20 mA output can be assigned to specific pH or ORP values, for a more refined output.

1. Press ENT key and use ▲ or ▼ keys to scroll till LCD displays 'r n g'. Press ENT again. Upper display shows pH value, '0.00 pH' while lower display shows 'r 4.0'. This is the set up page for the pH or ORP output range setting for the 4mA output current.
2. Assign pH or ORP value to 4 mA output current. Use ▲ or ▼ keys to change pH or ORP value. Press ENT to accept value.
3. Upper display shows pH value, '14.00 pH' while lower display shows 'r 20.0'. This is the set up page for the pH or ORP output range setting for the 20mA output current.
4. Assign pH or ORP value to 20 mA output current. Use ▲ or ▼ keys to change pH or ORP value. Press ENT to accept value.
5. Press both ▲ or ▼ keys together to return to 'MEAS' mode.

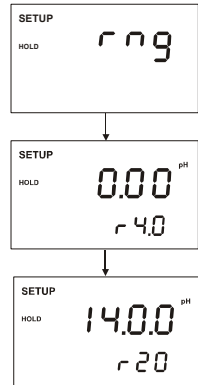

6.3 Temperature Compensation Setting (Unavailable in ORP mode)

pH values other than pH 7.00 are affected by temperature. Under varying temperature conditions, use ATC to compensate pH values. If temperature of bath is constant, and a temperature probe is not available, Manual Temperature Compensation can be utilized.

6.3.1 Automatic Temperature Compensation

For automatic temperature compensation (ATC), connect ATC probe to transmitter, as described in Section 2.2.2.

1. Press ENT key to enter SETUP mode. Press ▲ or ▼ keys to scroll through sub-menus till LCD displays '**SET °C**'. Press ENT.
2. Display shows '**ATC On**' or '**ATC Off**'. Use ▲ or ▼ keys to select '**ATC On**', and press ENT.
3. Dip ATC probe into a solution of known temperature (i.e. a temperature bath). Allow time for temperature probe to acclimatize with surrounding bath temperature. If temperature readings are inaccurate, calibrate temperature probe as described in steps 4 and 5.

If temperature readings are correct, press ENT key and go to step 6.

4. Use ▲ or ▼ keys to adjust correct temperature value (i.e. temp. of temp. bath). Readings can be adjusted in increments of 0.1 °C. Maximum adjustments allowed is ± 5 °C.
5. Once you have adjusted the correct temperature, press ENT key.
6. Press ▲ and ▼ keys together, to return to MEAS mode.

The ATC indicator will light up on the LCD.

NOTE: If you are using a temperature probe, the probe must be submersed in the liquid you are measuring.

6.3.2 Manual Temperature Compensation

1. Make sure the transmitter is on. Press ENT key and use ▲ or ▼ keys to select '**SET °C**'.

2. Press ENT key. Primary display shows 'ATC' and secondary display shows 'On' or 'OFF'. Use ▲ or ▼ keys to select 'ATC Off'. Press ENT.
3. Primary display shows temperature (default is 25.0), and secondary display shows 'P °C'. This is the set up page for setting the temperature of your transmitter to the temperature of your process or sample by using an accurate thermometer as reference.
4. Use ▲ or ▼ keys to set the transmitter to the temperature of your process or sample. Press ENT key.
5. Primary display shows temperature (default is 25.0), and secondary display shows 'C °C'. This is the set up page to input to your transmitter the temperature of your calibration solutions.
6. Use ▲ or ▼ keys to set the transmitter to the temperature of your calibration solutions. Press ENT key.
- 6.7. Press ▲ and ▼ keys together, to return to MEAS mode.

The transmitter will now compensate pH readings for the manually set temperature (values taken from P °C').

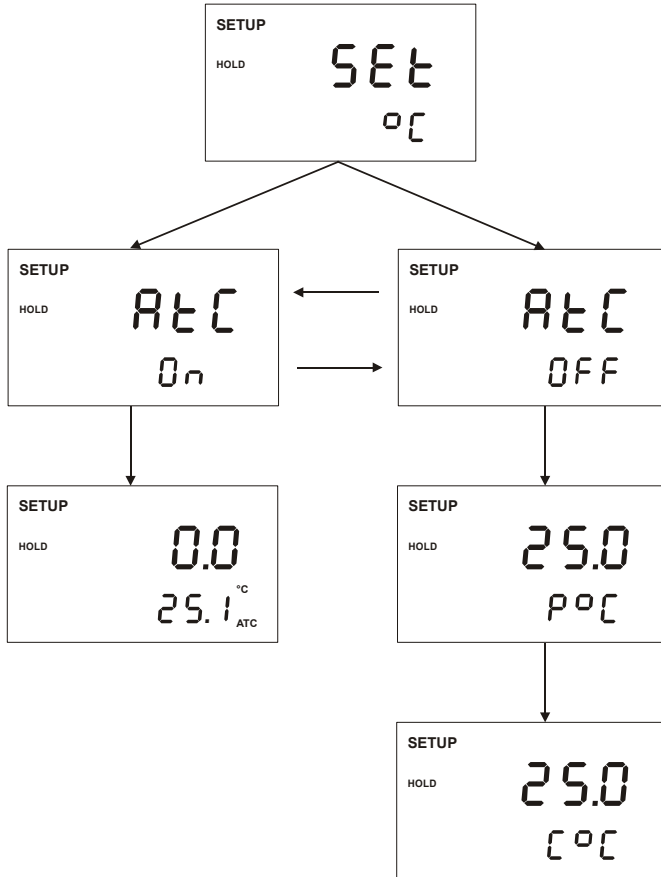

Temperature Compensation Setting Chart – alpha pH 500 Transmitter

6.4 HOLD Current Setting

When Transmitter is in CAL or SETUP modes, it automatically goes into a 'HOLD' mode.

To indicate Transmitter is in 'HOLD' mode, output current can be set to 22 mA output by activating the 'HLD On'.

1. Press ENT key and use ▲ or ▼ keys to scroll till LCD displays 'SET' in the upper display; and 'HLD' in the lower display. Press ENT again.
2. Upper display now shows 'HLD'. Lower display will show either 'OFF' or 'On'. Use ▲ or ▼ keys to toggle between 'On' of 'OFF'. Press ENT to accept selection.
3. Press ▲ and ▼ keys together, to return to MEAS mode.

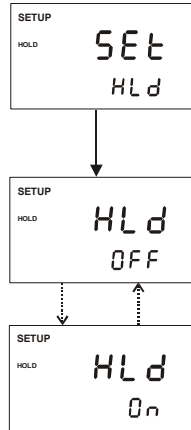

NOTE: If 'HLD' is set to 'OFF', then current output will be equivalent to last measured value.

6.5 Out-of-Range Current Setting

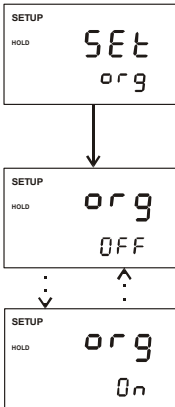

If pH or ORP readings exceed the scale, LCD displays 'Or' (over-range), or 'Ur' (under-range). Transmitter current output can be set to 3.8 mA to indicate Out-of Range situation.

1. Press ENT key and use ▲ or ▼ keys to scroll till LCD displays 'SET' in the upper display; and 'org' in the lower display. Press ENT again.
2. Upper display now shows 'org'. Lower display will show either 'OFF' or 'On'. Use ▲ or ▼ keys to toggle between 'On' of 'OFF'. Press ENT to accept selection.
3. Press ▲ and ▼ keys together, to return to MEAS mode.

NOTE: If 'org' is set to 'OFF', under-range will be set at 4 mA, while over-range will be set at 20 mA.

6.6 Configuration

6.6.1 Selecting pH or ORP Mode of Operation

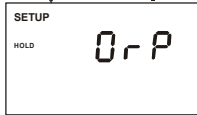
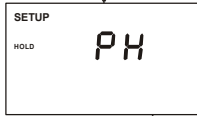

The alpha pH 500 transmitter is not only a pH transmitter, but also an ORP transmitter. When configured to measure ORP, electrode must be changed and calibrated (see Section 5.3 for calibration procedure). ORP values are measured and displayed in mV only.

1. Press ENT key and use ▲ or ▼ keys to scroll till LCD displays 'COF' (Configuration). Press ENT again.
2. LCD displays 'PH'. Transmitter is set to operate as a pH Transmitter. Use ▲ or ▼ keys to change from 'PH' to 'ORP', if this Transmitter is to operate as an ORP Transmitter.
3. Press the ENT key to accept selection.
4. Press ▲ and ▼ keys together, to return to MEAS mode.
5. If the readings on the Transmitter is fluctuating wildly, please proceed to Section 6.6.2, for a possible solution.

6.6.2 Selecting Asymmetrical or Symmetrical Mode of Operation

In some applications, there may be some electrical interference in the sample, where the electrode is installed. The sensitive electrode picks up the signal and the effect is displayed on the LCD.

If the electrical interference is from an AC source, the readings on the LCD fluctuates wildly. If the source is DC, then readings will be stable, but at a wrong value.

In such cases, switch the Transmitter to the Symmetrical mode as below:

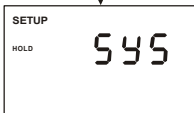
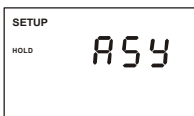

1. Press ENT key and use ▲ or ▼ keys to scroll till LCD displays 'COF' (Configuration). Press ENT again.
2. LCD displays either 'PH' or 'ORP' depending on requirement. Press ENT key.

3. LCD displays '**ASY**' (asymmetrical operation). Use ▲ or ▼ keys to select for '**SYS**' (symmetrical mode of operation). Press ENT key again.
4. Press ▲ and ▼ keys together, to return to MEAS mode.

7 PROBE CARE AND MAINTENANCE

Since your pH electrode is susceptible to dirt and contamination, clean it every one to three months depending on the extent and condition of use.

NOTE: For specialty electrode care, consult the instruction manual included with your electrode.

pH electrode storage

For best results, always keep the pH bulb wet. Use the protective electrode storage bottle or rubber cap filled with electrode storage solution to store your electrode. Also, you can store in a pH 4 buffer with 1/100 part of saturated KCl. Other pH buffers are OK for storage, but NEVER use distilled water for storage.

After measuring

1. Rinse the pH electrode and reference junction in de-ionized water.
2. Store the electrode as recommended above in “pH electrode storage,” or as recommended by the manufacturer.
3. Prior to next use, rinse the liquid junction with de-ionized water and tap dry – never wipe electrode.

NOTE: If this does not restore electrode to normal response, see “Reactivating the pH electrode” section below.

pH electrode cleaning

- **Salt deposits:** Dissolve the deposits by immersing the electrode in tap water for ten to fifteen minutes. Then thoroughly rinse with distilled water.
- **Oil/Grease film:** wash electrode pH bulb gently in some detergent and water. Rinse electrode tip with distilled water or use a general purpose electrode cleaner (see ordering information).
- **Clogged reference junction:** Heat a diluted KCl solution to 60 to 80 °C. Place the sensing part of the electrode into the heated solution for about 10 minutes. Allow the electrode to cool in some unheated KCl solution.
- **Protein deposits:** Prepare a 1% pepsin solution in 0.1 M of HCl. Set the electrode in the solution for five to ten minutes. Rinse the electrode with distilled water.

Reactivating the pH electrode

If stored and cleaned properly, your pH electrode should be ready for immediate use. However, a dehydrated bulb may cause sluggish response. To rehydrate the bulb, immerse electrode in a pH 4 buffer solution for 10 to 30 minutes. If this fails, the electrode requires activation.

pH electrode activation (for glass body electrodes only)

WARNING: Only qualified persons proficient with the safe handling of dangerous chemicals should perform the procedure below. Provide proper containers, fume hoods, ventilation, and waste disposal. Safety goggles and protective clothing must be worn while performing this procedure.

1. Dip or stir the pH electrode in alcohol for 5 minutes.
2. Leave the electrode in tap water for 15 minutes.
3. Dip and stir the electrode in concentrate acid (such as HCL or H₂SO₄) for five minutes.
4. Repeat Step 2.
5. Dip and stir in strong base (NaOH) for five minutes.
6. Leave for 15 minutes in tap water.
7. Now test with standard calibration buffer solutions to see if electrode yields acceptable results. You may repeat step 3 through 6 up to three times for better response. If response does not improve, then your electrode is no longer functioning. Replace with new electrode – call your distributor for information.

8 TROUBLE SHOOTING GUIDE

| Problem | Cause | Solution |
|-------------------------|--|---|
| Power on but no display | <ul style="list-style-type: none"> a). Loose connections b). Cables not in correct polarity (+ and – position). | <ul style="list-style-type: none"> a). Check cables are making good contact. b). Re-wire loop cables with correct polarity. |
| Unstable readings | <ul style="list-style-type: none"> a). Air bubbles in probe. b). Dirty probe. c). Probe not deep enough in sample. d). External noise pickup or induction caused by nearby electric motor. e). Severe Reference junction fouling. | <ul style="list-style-type: none"> a). Tap probe to remove bubbles. b). Clean the probe and re-calibrate. c). Make sure sample entirely covers the probe sensors. d). Switch to Symmetrical mode and connect PMP. e). Replace probe. |
| Slow response | <ul style="list-style-type: none"> a). Dirty / Oily probe. | <ul style="list-style-type: none"> a). Clean probe. See “Probe Care & Maintenance”, Section 7. |

9 SPECIFICATIONS

| SPECIFICATIONS | DESCRIPTIONS |
|------------------------------------|--|
| pH Range | 0.00 to 14.00 pH |
| Resolution / Accuracy | 0.01 pH / ± 0.01 pH |
| Temperature Range | -10.0 to 110.0 °C |
| Resolution / Accuracy | 0.1 °C / ± 0.5 for °C |
| Millivolt Range | -1000 to +1000 mV |
| Resolution / Accuracy | 1 mV / ± 2 mV |
| Temperature Compensation | Auto (Pt 100) / Manual (from 0 to 100 °C) |
| Number of calibration points | 2 |
| Number of calibration buffers | USA: 4.01, 7.00, 10.01; NIST: 4.01, 6.86, 9.18 |
| Inputs | Asymmetrical / Symmetrical |
| Output | 4.0 to 20.0 mA (Galvanically Isolated) |
| Over- / Under range current output | |
| 'ON' Select | 3.8 mA |
| 'OFF' Select | 4 mA (under-range) & 20 mA (over-range) |
| HOLD current output | |
| 'ON' Select | 22 mA |
| 'OFF' Select | Last measured current value |
| Display | Custom Dual LCD |
| Power Requirements | 12 to 24 VDC |
| Load Resistance | Max. 600 Ω |
| Dimension / Weight | 96 x 96 x 66 mm / 210 g |

10 TECHNICAL DIMENSIONS

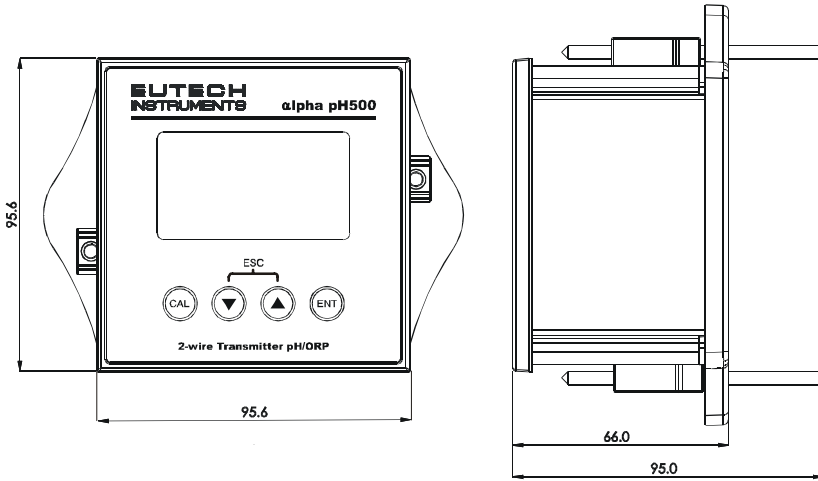

11 ACCESSORIES

EUTECH INSTRUMENTS

Replacement Transmitter and Transmitter accessories

| Ordering Code No. | Item |
|-------------------|--|
| EC-PHCTP0500 | Alpha pH/ORP 2-wire LCD Transmitter |
| EC-ARTSO-05B | Combination pH electrode with 5m cable |
| EC-ARGTSO-05B | Combination pH electrode with PMP and 5m cable |
| EC-100GTSO-05B | Combination pH electrode with PT 100, PMP and 5m cable |
| EC-DA93506-05B | Combination pH electrode, submersible, with 5m cable |
| EC-HTAUTSO-05B | Combination Gold ORP electrode with PMP and 5m cable |
| EC-HTPTTSSO-05B | Combination Platinum ORP electrode with PMP and 5m cable |

Calibration Solutions

| Ordering Code No. | Item |
|-------------------|--|
| EC-BU-4BT | pH 4.01 buffer solution, 480 ml bottle |
| EC-BU-7BT | pH 7.00 buffer solution, 480 ml bottle |
| EC-BU-10BT | pH 10.01 buffer solution, 480 ml bottle |
| EC-BU-4BS | pH 4.01 buffer sachets, 20 ml x 20 pcs. |
| EC-BU-7BS | pH 7.00 buffer sachets, 20 ml x 20 pcs. |
| EC-BU-10BS | pH 10.01 buffer sachets, 20 ml x 20 pcs. |
| EC-RIN-WT | pH De-ionized water rinse sachets, 20 ml x 20 pcs |
| EC-AST-PK | pH sachet assortment pack – 5 each of pH 4.01, pH 7.00, pH 10.01 and de-ionized water sachets per box. |
| EC-DPC-BT | Protein cleaning solution for pH electrode |
| EC-RE-005 | Storage solution for pH electrode |

Note: pH buffer solutions (480-ml bottle) have ± 0.01 pH accuracy at 25 °C. Sachets are individually sealed, single use pouch containing 20 ml of fresh, contamination free calibration solution. pH buffer sachets have ± 0.01 pH accuracy at 25°C and conductivity sachets have $\pm 1\%$ accuracy at 25°C.

OAKTON INSTRUMENTS

Replacement Transmitter and Transmitter accessories

| Ordering Code No. | Item |
|-------------------|---|
| 56717-20 | pH 500 pH/ORP 2-wire LCD Transmitter with display |
| 35807-20 | pH/Temp electrode with PMP and 10-ft cable |
| 35801-21 | Platinum ORP electrode with 10-ft cable |
| 05994-90 | BNC to spade lug adapter |

Calibration Solutions

| Ordering Code No. | Item |
|-------------------|---|
| 00654-00 | pH 4.01 calibration buffer, 1 pint |
| 00654-04 | pH 7.01 calibration buffer, 1 pint |
| 00654-08 | pH 10.01 calibration buffer, 1 pint |
| 35653-01 | pH 4.01 calibration buffer solution pouches, 20/box |
| 35653-02 | pH 7.00 calibration buffer solution pouches, 20/box |
| 35653-03 | pH 10.00 calibration buffer solution pouches, 20/box |
| 35653-00 | rinse water solution pouches, 20/box |
| 35653-04 | Assortment pack – 5 each of pH 4.01, pH 7.00 and pH 10.00 solution pouches. |
| 00653-06 | Electrode cleaning solution |
| 00653-04 | Electrode storage solution |

To order OAKTON accessories, contact your OAKTON distributor.

12 WARRANTY

This transmitter is supplied with a one-year warranty against significant deviations in material and workmanship from date of purchase and a six-month warranty for probe. Each instrument will have a warranty card with a specific serial number. The warranty card must be endorsed by the Authorized Distributor at the point of sale.

If repair or adjustment is necessary and has not been the result of abuse or misuse within the designated period, please return – freight pre-paid – and correction will be made without charge. Eutech Instruments / Oakton Instruments will determine if the product problem is due to deviations or customer misuse.

Out of warranty products will be repaired on a charged basis.

Exclusions

The warranty on your instrument shall not apply to defects resulting from:

- Improper or inadequate maintenance by customer
- Unauthorized modification or misuse
- Operation outside of the environment specifications of the products

13 RETURN OF ITEMS

Authorization must be obtained from our Customer Service Department or authorized distributor before returning items for any reason. A “Return Goods Authorization” (RGA) form is available through our authorized distributor. Please include data regarding the reason the items are to be returned. For your protection, items must be carefully packed to prevent damage in shipment and insured against possible damage or loss. Eutech Instruments/ Oakton Instruments will not be responsible for damage resulting from careless or insufficient packing. A restocking charge will be made on all unauthorized returns.

NOTE: Eutech Instruments Pte Ltd / Oakton Instruments reserve the right to make improvements in design, construction, and appearance of products without notice.

For more information on our products, contact your nearest distributor or visit our website listed below:

| | | |
|--|---|-------------------------------|
| <p>Oakton Instruments P.O Box 5136, Vernon Hills, IL 60061, USA Tel: (1) 888-462-5866 Fax: (1) 847-247-2984 E-mail: info@4oakton.com Web-site: www.4oakton.com</p> | <p>Eutech Instruments Pte Ltd. Blk 55, Ayer Rajah Crescent, #04-16/24 Singapore 139949 Tel: (65) 6778 6876 Fax: (65) 6773 0836 E-mail: marketing@eutechinst.com Web-site: www.eutechinst.com</p> | <p>Distributed by:</p> |
|--|---|-------------------------------|