

# Ultrafilter Installation, Cleaning and Storage

An ultrafilter (UF) is a great tool for keeping the water flowing to the PBR free of particulates and extending the life of the 0.1 µm filter on the reactor. To maintain the integrity of your ultrafilter ensure that the filters never dry out or freeze. The following are links to the important procedures for maintaining your ultrafilter and the frequency they should be done:

- [Membrane Installation](#) - Upon set up, or UF membrane replacement
- [Flushing](#) - After Membranes installation or to clear storage solution
- [Backflush](#) - Once / week - once / 4 weeks
- [Freshwater Backflush](#) - Can replace Backflush when higher (30-60 PSI) freshwater pressure is available and marine algae is being grown in the PBRs.
- [Chemical Clean](#) - Annually or up to every 3 months
- [Shutdown and storage](#) - When the header is shutdown for the season (2+ weeks)

## Membrane Installation

1. Unplug Header Power and turn off water supply into Header Tank.
2. Connect the UF Drain Line and direct it to waste.

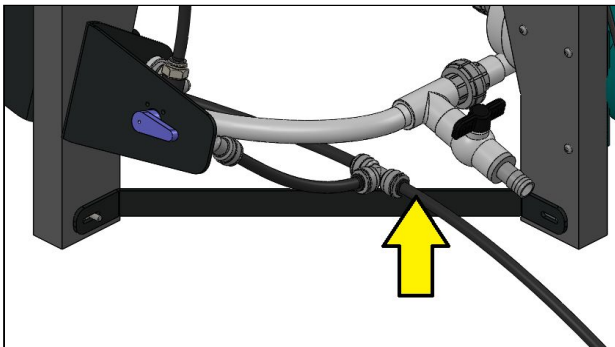

3. Orient Both Backflush Valves to Drain (sideways).

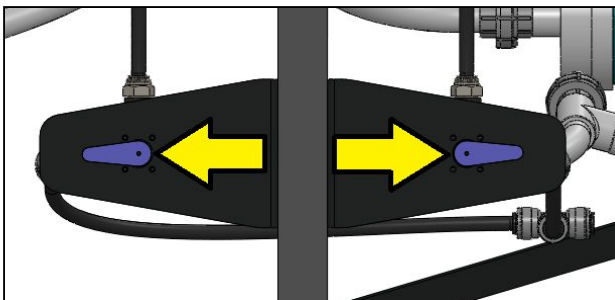

4. Disconnect the John Guest fittings from the Top Ultrafilter Tee (remove red clips and depress tab to disconnect tubing).

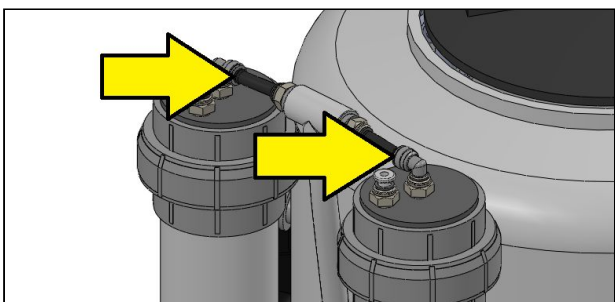

5. Loosen the Top Unions and remove End Caps

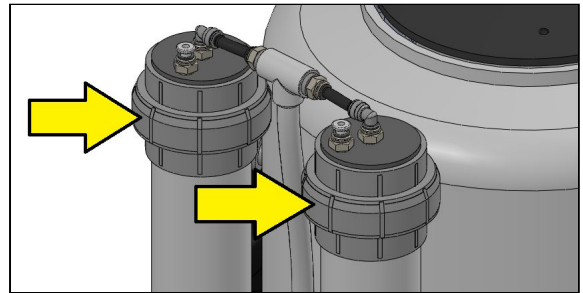

6. Remove Old UF Membranes (if applicable).

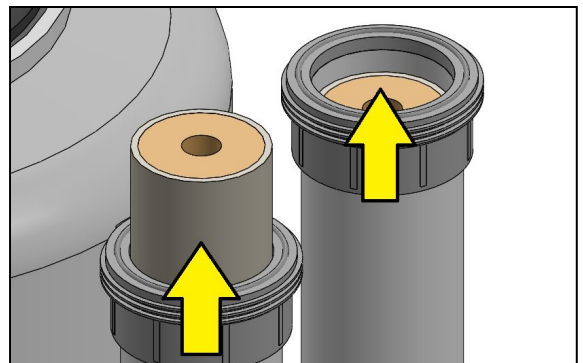

7. Remove New UF Membranes from packaging and insert into housings.

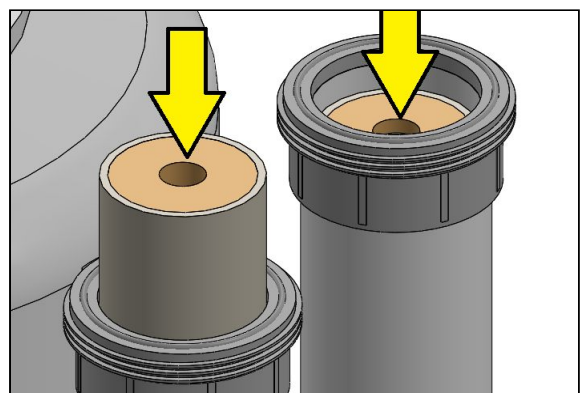

- Replace End Caps and reconnect Top Tee (Tighten Unions securely - Strap Wrench recommended).
- Do **NOT** leave the ultrafilters without flow as they will dry out and crack, rupturing the membranes. Either establish flow or store wet to prevent damage to the filters.

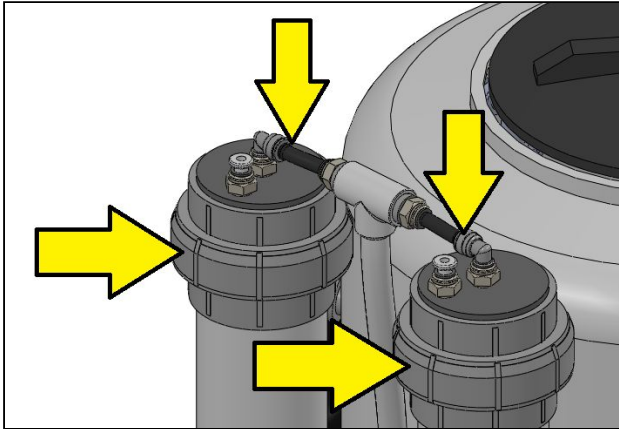

## Flushing

- Unsure Header Power is disconnected.
- Disconnect Communal UF Drain's Plug

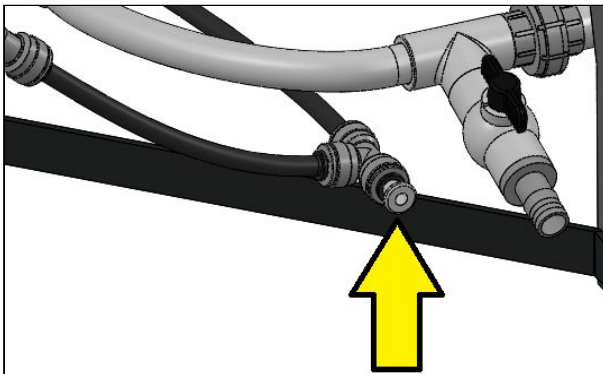

- Connect UF Drain Line and direct it to waste.

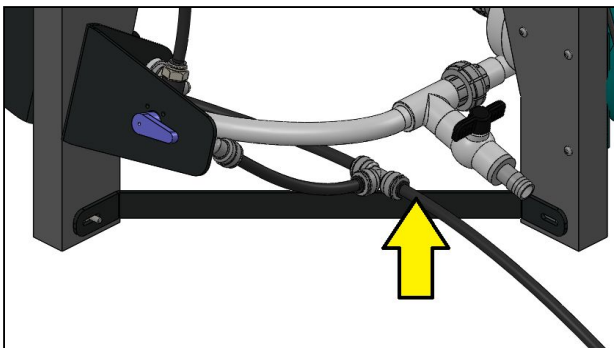

- Drain Storage solution by orienting UF Backflush Valves to Drain (outwards).

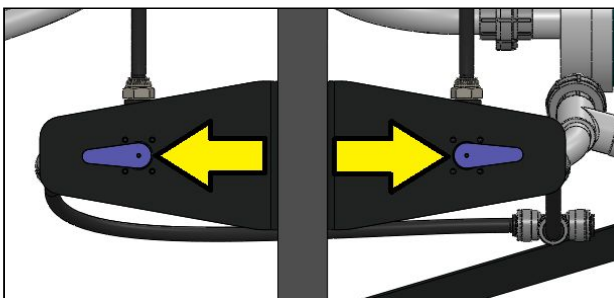

- Once drained, direct UF Backflush Valves to filtering (upwards)

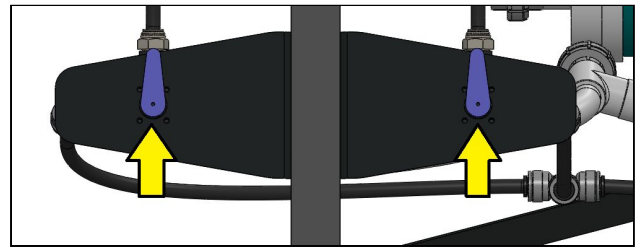

- Ensure Header Drain is closed.

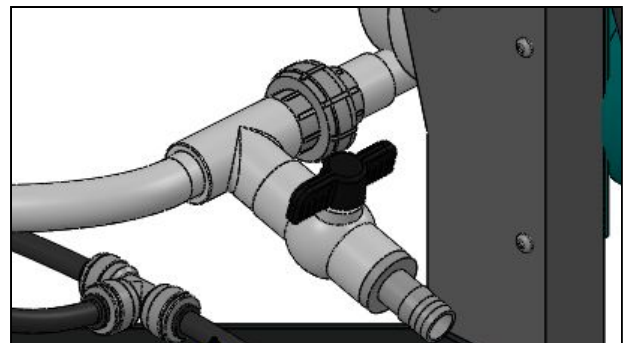

- Fill Header above the Low Float Switch with freshwater ~20 gal.

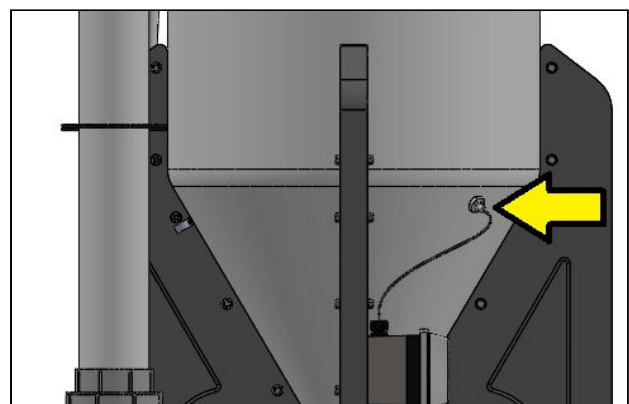

8. Ensure PBR Supply Ball Valve(s) are closed

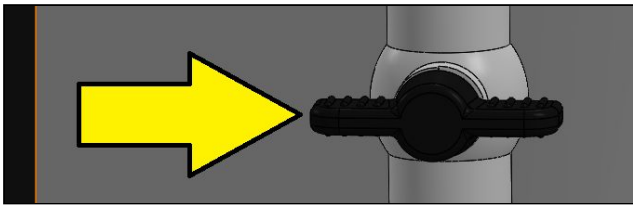

9. Reconnect Header power for **5 minutes**

10. Disconnect power.

11. Open Header Drain and direct both UF Backflush Valves to Drain

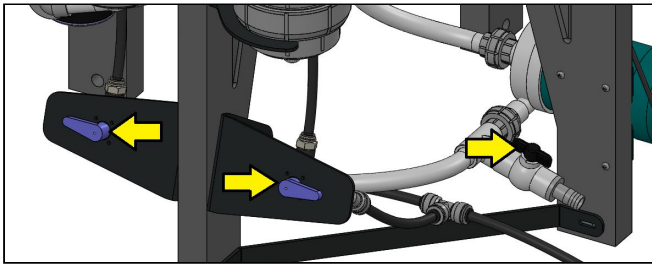

12. Repeat steps 5-11

13. Once drained, direct UF Backflush Valves to filtering (upwards)

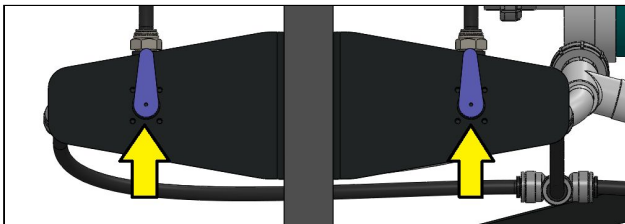

14. Close Header Drain.

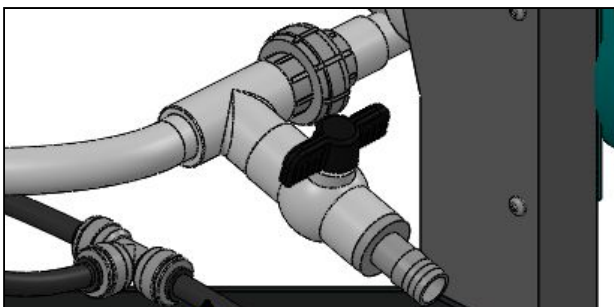

15. Open culture water supply **into** the Header and fill above Float Switch.

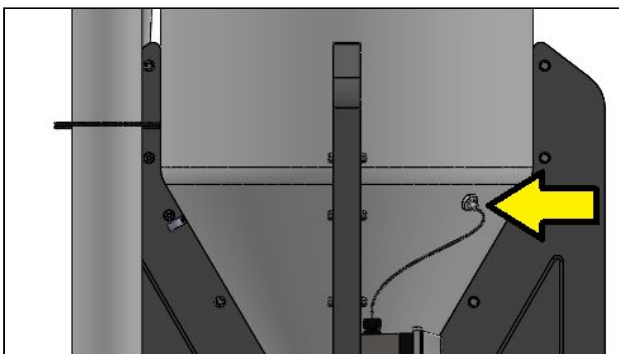

16. Shut off water supply **into** Header

17. Connect Header power for **5 minutes**

18. Disconnect power.

19. Open Header Drain and direct both UF Backflush Valves to Drain

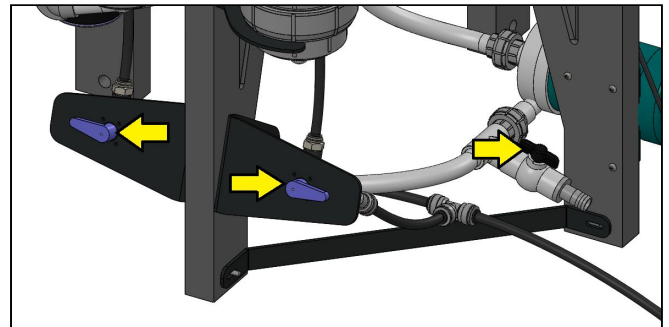

20. Once drained, direct UF Backflush Valves to filtering (upwards)

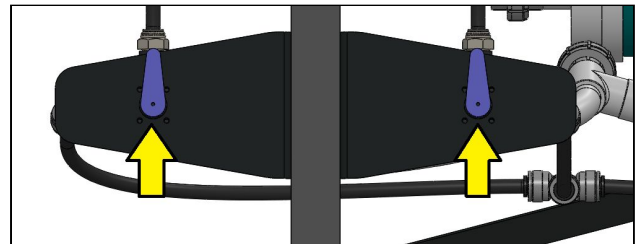

21. Close Header Drain.

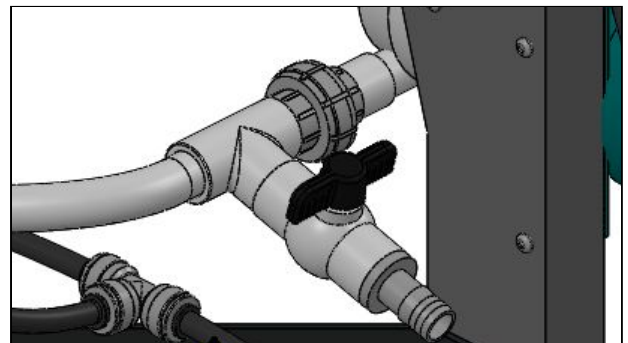

22. Open water supply into Header

23. Open PBR Supply Ball Valve(s)

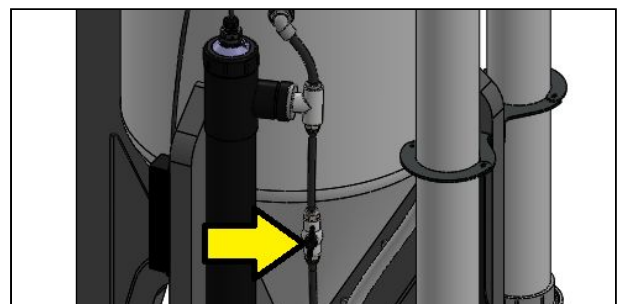

24. Reconnect Header Power.

## Backflush

1. Close water supply ball valves to PBRs.

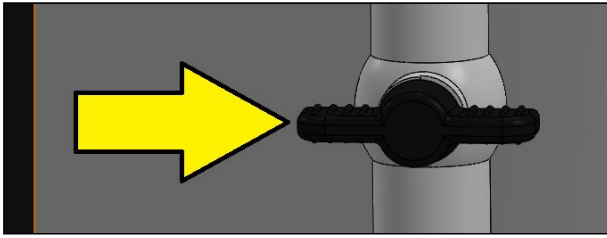

2. Ensure backflush drain tubing is connected and routed to waste.

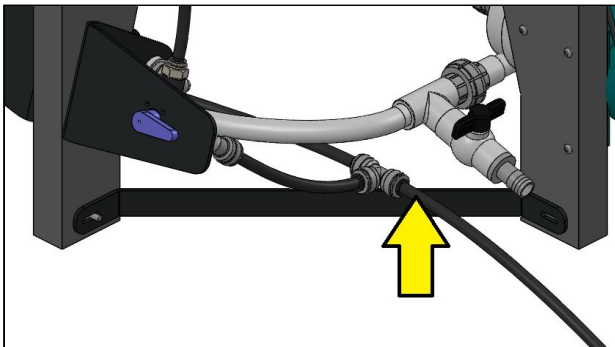

3. Direct left backflush valve leftward to allow the filter to backflush for 1 minute or until effluent runs clear.

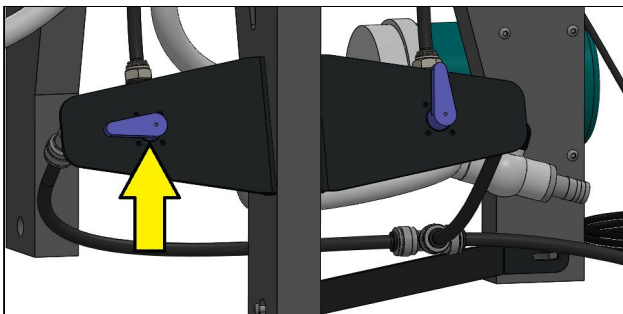

4. Return Backflush Ball Valve to vertical so both filters are directed through filter.

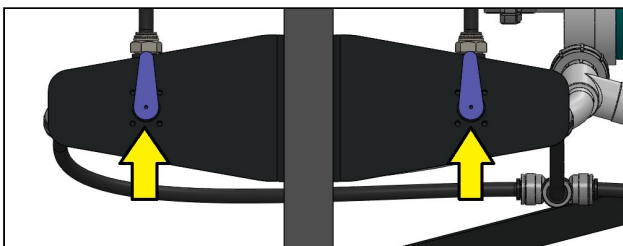

5. Direct right UF Backflush Valve to drain to allow the filter to backflush for 1 minute or until effluent runs clear.

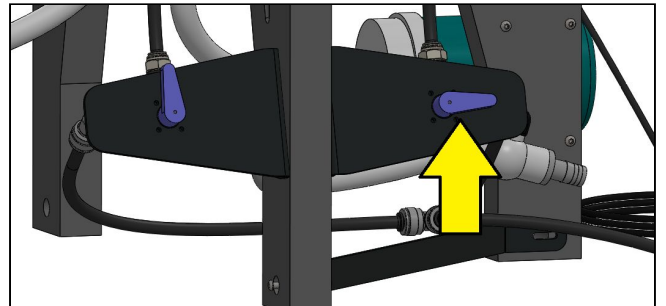

6. Return Backflush ball valve to vertical to direct flow through filter.

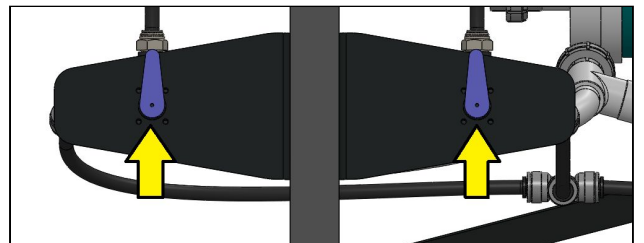

7. Open water supply ball valves to PBRs.

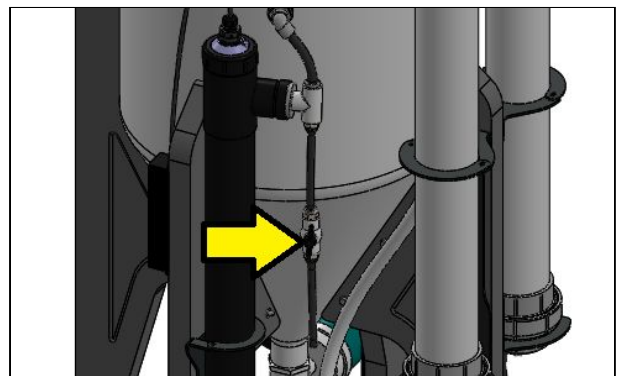

## Freshwater Backflush

1. Close water Supply Ball Valve(s) to PBR(s).

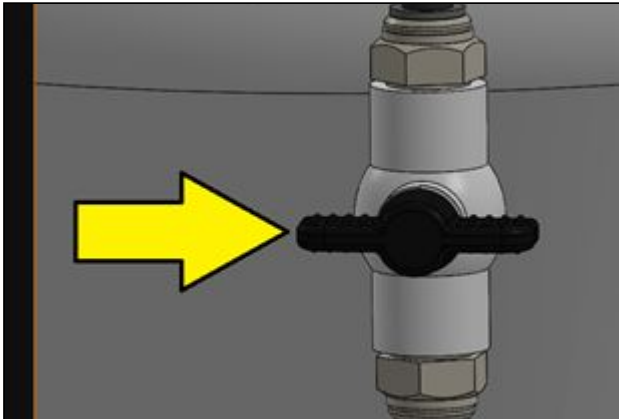

2. Ensure backflush drain tubing is connected and routed to waste.

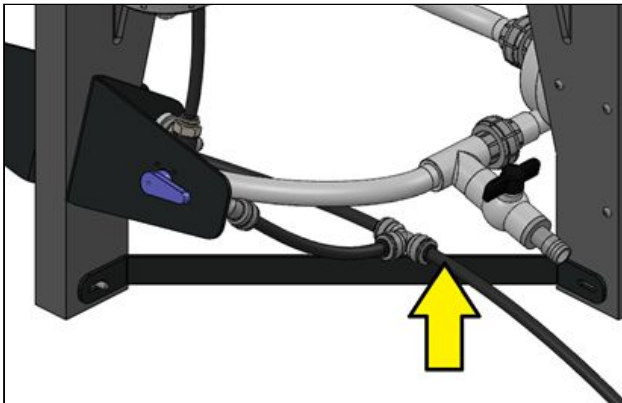

3. Disconnect Power to Header
4. Open both UF Backflush Valves to Drain.

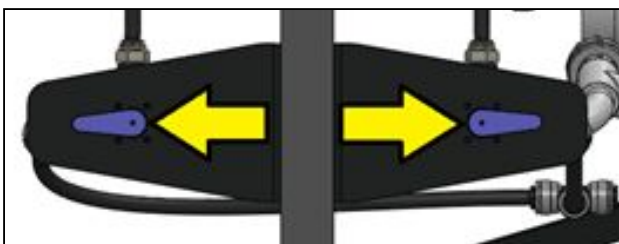

5. Disconnect the John Guest fittings from the Top Ultrafilter Tee (remove red clips and depress tab to disconnect tubing).

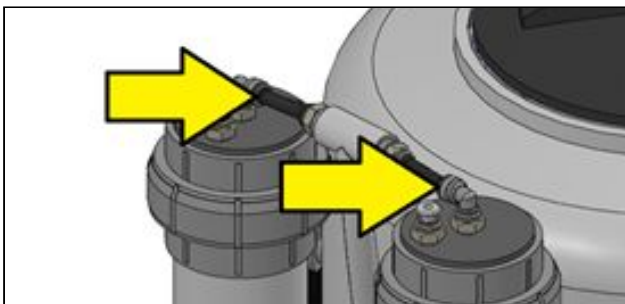

6. Connect your FW supply to the center fittings on the UF Caps.

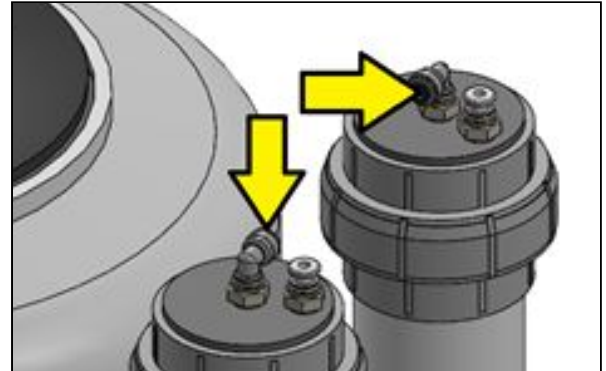

7. Turn on Freshwater Supply to backflush for 10 minutes.
8. Turn off supply and disconnect it to allow both ultrafilters to drain.
9. Reconnect Top Tee John Guest Fittings

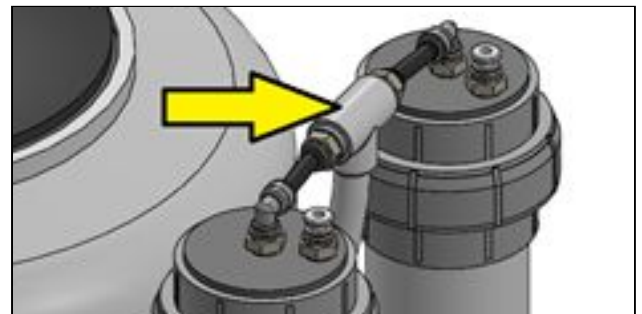

10. Return Backflush Valves to Filtering

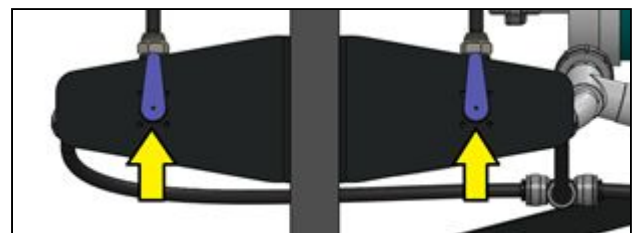

11. Reconnect Header Power & Open PBR Supply Ball Valve(s)

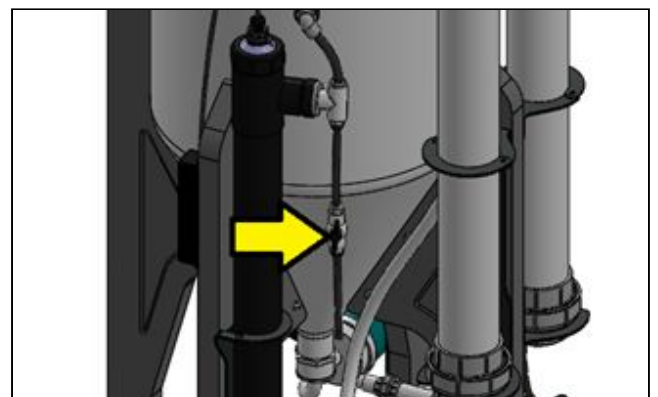

## Chemical Clean

Every 3-6 months, or between algae cultures, it is beneficial to perform a series of Chemical Cleans to restore UF flow. The procedure requires standard cleaning agents used for cleaning of the PBR: Steris CIP/NaOH, Muriatic Acid or HCl. An Acid Backflush without the base is okay; however, a Base Backflush must be followed with a rinse and an Acid Backflush.

### 1. Backflush

1. [Backflush](#) filters as described above, but omit step 7 to leave PBR Supply Ball Valves **closed**

### 2. Drain

1. Close-off water supply **into** Header.
2. Disconnect header from power.
3. Route Header Drain to waste.

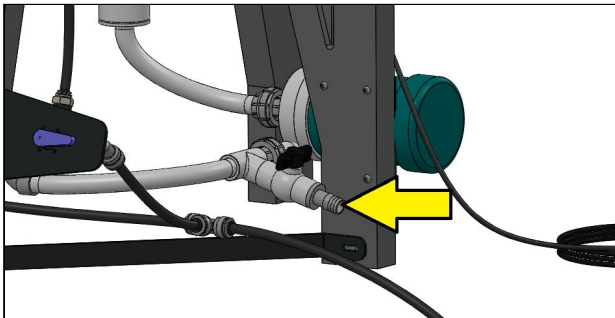

4. Open drain to empty header.

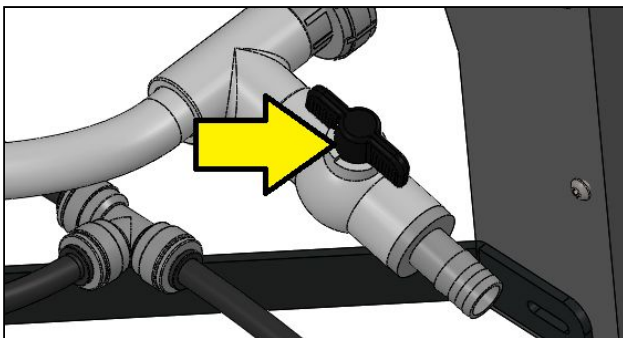

5. Close drain once empty (If tank appears dirty, this is a good opportunity to clean it).

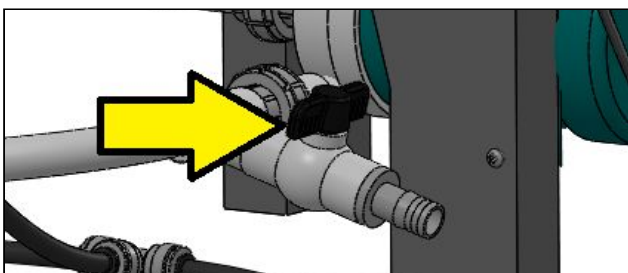

### 3. Base Backflush

1. Add 20 gallons of **freshwater** to the header through the lid. Ensure water is above low float switch.

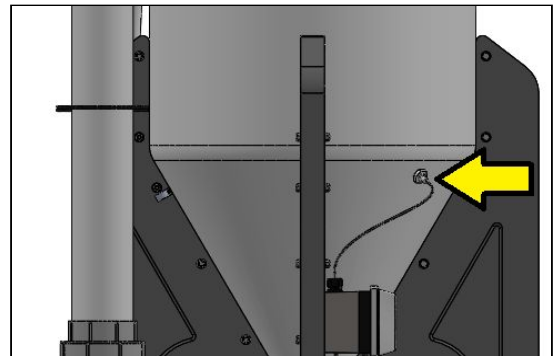

2. Reconnect Power.
3. Add 300 mL Steris CIP 100 (15 mL/L)
4. Circulate cleaner for 5 minutes
5. Disconnect power and wait for **30 minutes**.
6. Reconnect Power
7. Backflush **each** filter for **1 min** by switching the 3 way ball valves as per the [Backflush](#) procedure above.
8. Disconnect power.
9. [Drain](#) header. Ensure drain tubing is still directed to waste.

### 4. Freshwater Rinse

1. Add 20 gallons of **freshwater** to the header through the lid. Ensure water is above low float switch.
2. Reconnect Power.
3. Circulate water for 5 minutes with PBR Supply Valve closed.
4. Disconnect power.
5. [Drain](#) the header.

## 5. Acid Backflush

1. Add 20 gallons of **freshwater** to the header through the lid. Ensure water is above low float switch.
2. Connect power.
3. Add 75 mL of muriatic acid (33% HCl)
4. Circulate cleaner for 5 minutes.
5. Disconnect Power
6. Wait 30 minutes
7. Reconnect power.
8. Backflush each filter for 1 min by switching the 3 way ball valves as per the [Backflush](#) procedure above
9. Disconnect power.
10. [Drain](#) Header. Ensure drain tubing is still directed to waste.

## 6. Two Freshwater Rinses

1. Repeat [Freshwater Rinse](#) two times.

## 7. Culture Water Rinse

1. Open Customer's Water Supply Ball Valve **into** Header.
2. Add at least 20 gallons of water from the customer's supply. Ensure water level is above the low float switch.
3. Reconnect Power.
4. Circulate for 5 minutes.
5. Disconnect Power.
6. [Drain](#) tank.

## 8. Refill Header

1. Allow the header to fill completely.
2. Reconnect power once water is above the low float switch.
3. Open Water Supply Ball Valves to PBRs

## Shutdown and Storage

1. Prepare ultrafilter storage solution
  - a. If ultrafilters **may** freeze prepare storage solution with glycerol
    - 7.9 L Reverse Osmosis (RO) or ultrafiltered (UF) fresh water
    - 2.1 L glycerol
    - 79 g sodium bisulfite
  - b. If ultrafilters are **not** at risk of freezing, glycerol can be excluded
    - 10 L RO or UF fresh water
    - 75 g sodium bisulfite
2. Perform [Chemical Clean](#) steps 1 - 5.
3. With power disconnected, drain water from ultrafilters by opening both backflush valves.

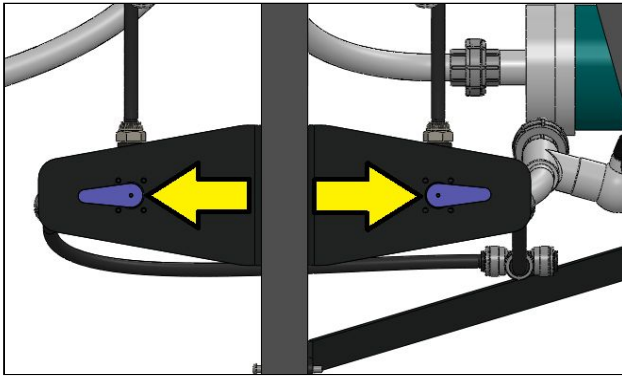

4. Plug communal UF Drain with ½" Plug to keep Storage solution in UF Housings (Leave Backflush Valve oriented to left and right to keep storage solution from entering the header).

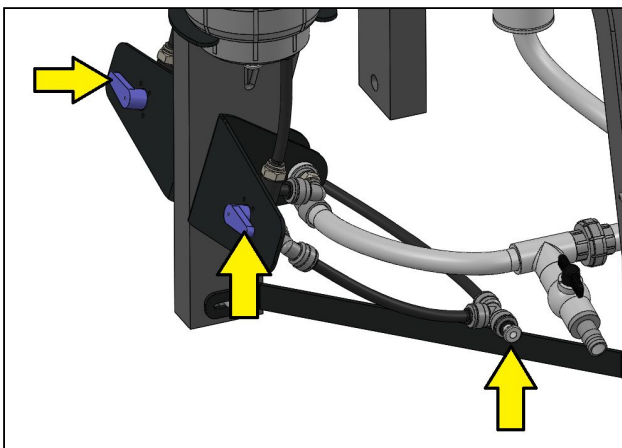

5. Disconnect the John Guest fittings from the Top Ultrafilter Tee (remove red clips and depress tab to

disconnect tubing).

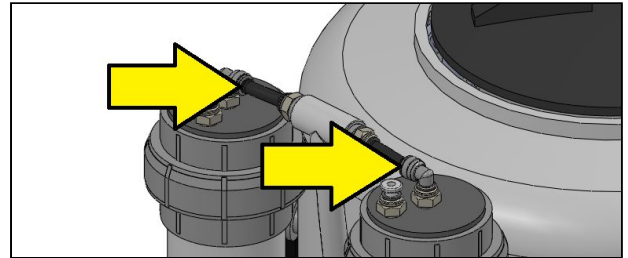

6. Loosen the Top Unions and remove End Caps.

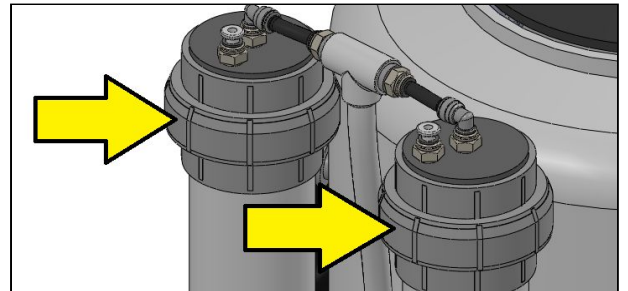

7. Pour Storage solution into Housings until UF Membranes are covered.

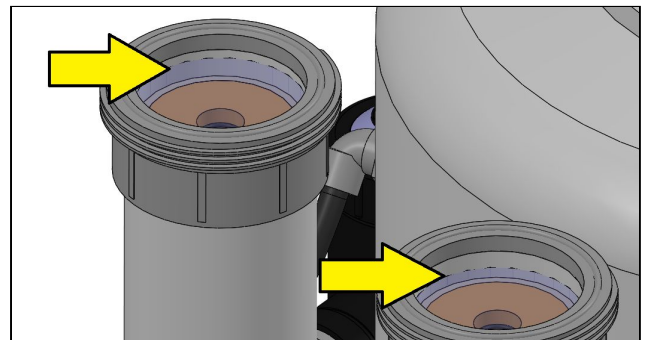

8. Replace End Caps and reconnect Top Tee (Tighten Unions securely - Strap Wrench recommended).

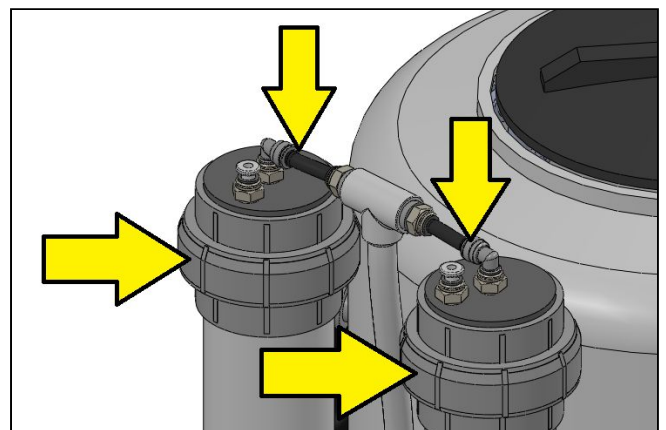

9. If storing for longer than 4 months storage solution will need to be refreshed.